



Clean Fittings

Metal seal fittings
Weld fittings

C o n t e n t s

Visual Index _01



Technical Data _02



Ordering Number _04



Metal Seal Fittings _05













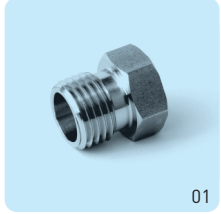
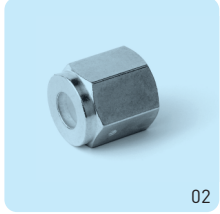

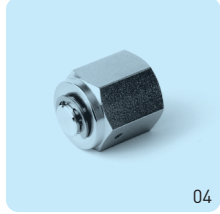





Weld Fittings _12

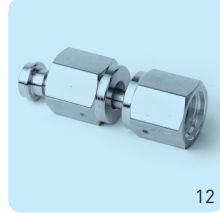

Assembly Instruction _17

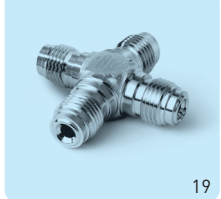

I METAL SEAL FITTINGS I

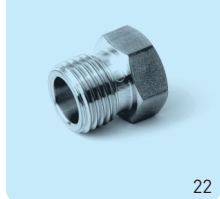
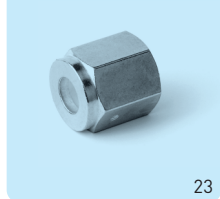
MALE NUT  01	FEMALE NUT  02	GASKET  03	CAP  04	PLUG  05	LONG GLAND-F  06
LONG GLAND-M  07	ATW LONG GLAND-F  08	ATW LONG GLAND-M  09	MICRO GLAND-F  10	MICRO GLAND-M  11	CLOSE COUPLING  12
BULKHEAD UNION  13	DOUBLE MALE UNION  14	MALE UNION ELBOW  15	MALE CONNECTOR  16	MALE ELBOW  17	MAEL UNION TEE  18
MALE UNION CROSS  19	B/W CONNECTOR  20	HVCR GLAND  21	HVCR MALE NUT  22	HVCR FEMALE NUT  23	

I WELD FITTINGS I

MICRO ELBOW  24	MICRO R-ELBOW  25	MICRO TEE  26	MICRO R-TEE  27	MICRO CROSS  28	MICRO TRIBOW  29
MICRO 45 ELBOW  30	MICRO R-UNION  31	LONG ELBOW  32	LONG TEE  33	LONG REDUCING TEE  34	LONG REDUCING UNION  35

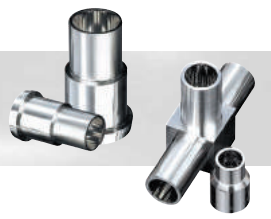

I METAL SEAL FITTINGS I

● Materials

• Glands, Bodies

Material	Designator	Specification
JIS_STD SUS316L(AOD)	GM	SEMI SPEC F20-0706E
Single Melt SUS316L(VOD)	SM	
Double Melt SUS316L(VAR)	DM	JIS SPEC CHEMICAL COMPOSITION
Double Melt SUS316L(VIM+VAR)	VM	

• Gaskets

Material	Designator	Specification
SUS316L	316L	ASTM A 167
Nickel	Ni	ASTM B 162

• Nut

Material	Designator	Specification
SUS316/316L	316/316L	ASTM A 276
SUS304	304	ASTM A 493 / JIS G 4318

● Pressure Ratings

- All ratings comply with calculations in accordance with ANSI Code for Pressure Piping B31.3, Process Piping.
- Working pressure ratings determined at room temperature with gasket materials shown.

● Plating

- Female nuts are plated with silver. Chemical processes used for cleaning, electropolishing, and passivation may remove plating. Damaged or removed plating may cause thread galling, damage of fitting components and prevention of a proper seal.

● Packing

- All metal seal fittings are double packaged in clean room. (Class 10 and 1000)
- Sealing part is protected with a plastic cap (yellow cap for BA, blue cap for EP)

● Feature

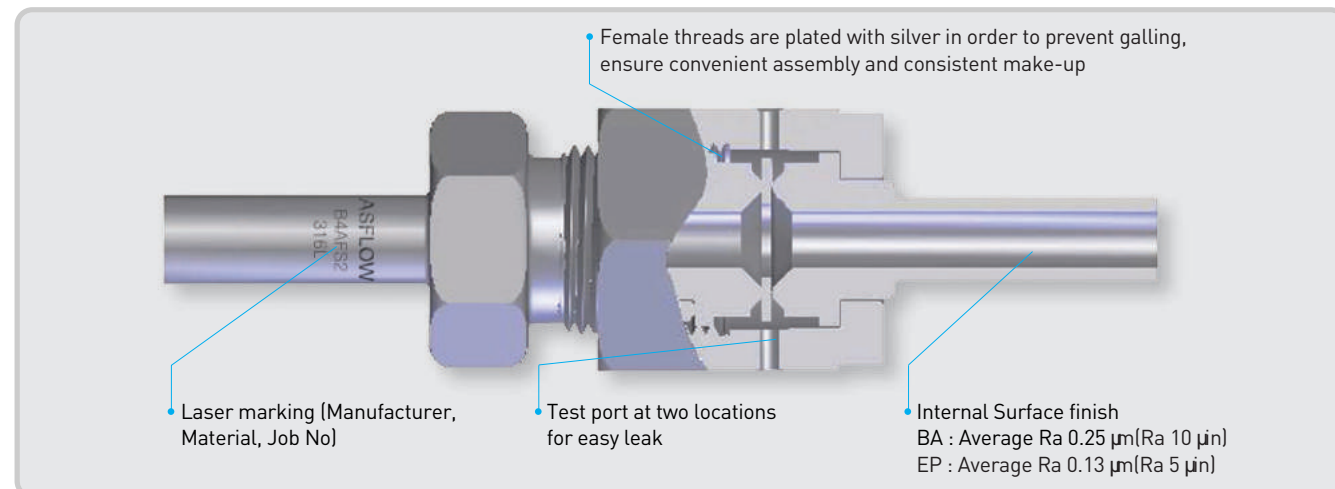

● Assembly

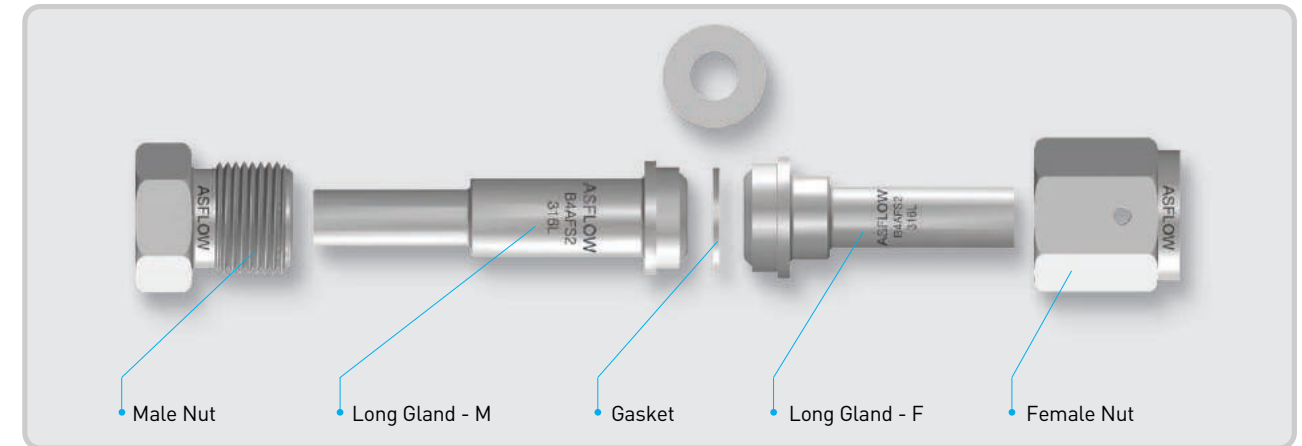

● Cleaning

Passivation in Nitric environment.

Ultra-sonic cleaning with minimum 18M of D.I water after passivation.

● Testing

Helium leak rate of 1×10^{-9} Torr. /s

International Standard, SEMI SPEC F1-96

I WELD FITTINGS I

● Materials

Material	Designator	Specification
JIS_STD SUS316L(AOD)	GM	SEMI SPEC F20-0706E
Single Melt SUS316L(VOD)	SM	
Double Melt SUS316L(VAR)	DM	JIS SPEC CHEMICAL COMPOSITION
Double Melt SUS316L(VIM+VAR)	VM	

● Feature

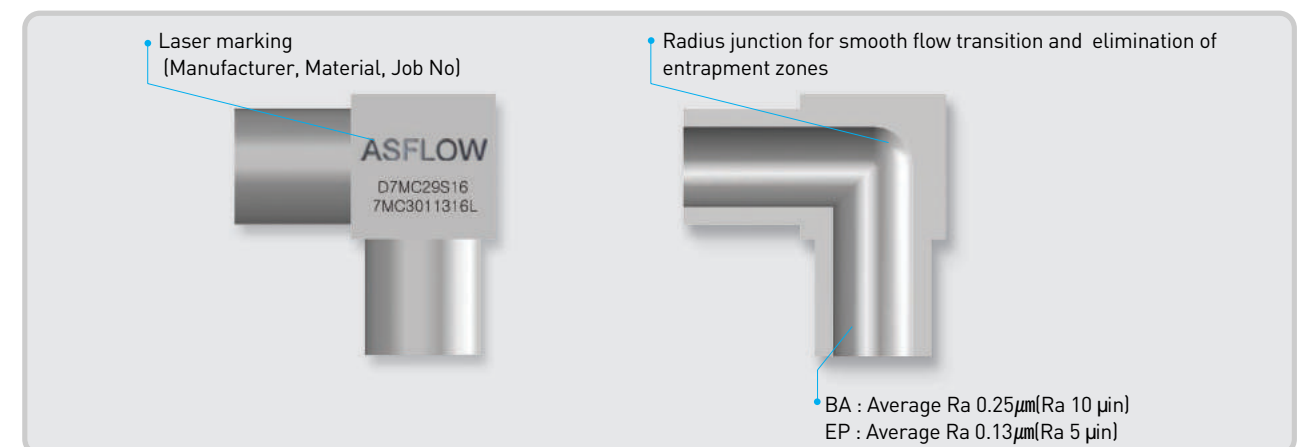

Ordering Number Sheet

I DESIGNATORS PROCESS I

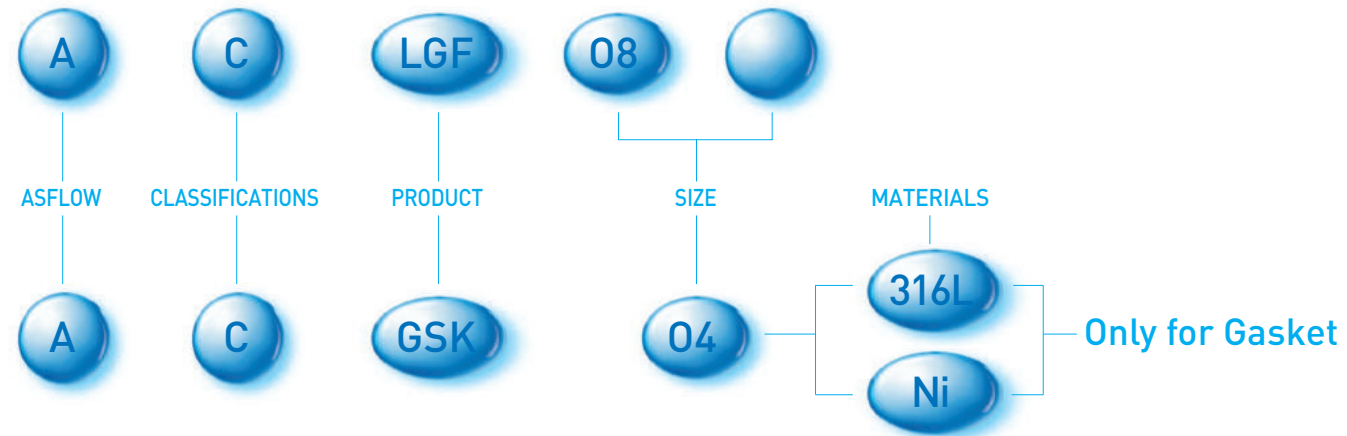

I DESIGNATORS SHEET I

BRAND		CLASSIFICATIONS		SIZE	
DESIGNATORS	: NAME	DESIGNATORS	: NAME	DESIGNATORS	: OD
A	: Asflow	C	: Clean fittings	04	: 1/4"
				06	: 3/8"
				08	: 1/2"
				10	: 5/8"
				12	: 3/4"
				16	: 1"

PRODUCT			
DESIGNATORS	: NAME	DESIGNATORS	: NAME
MN	: Male Nut	MUC	: Male Union Cross
FN	: Female Nut	BWC	: B/W Connector
GSK	: Gasket	HG	: HVCR Gland
CP	: Cap	HMN	: HVCR Male Nut
PG	: Plug	HFN	: HVCR Female Nut
LGF	: Long Gland-F	ME	: Micro Elbow
LGM	: long Gland-M	MRE	: Micro R-Elbow
ALGF	: ATW Gland-F	MT	: Micro Tee
ALGM	: ATW Gland-M	MRT	: Micro R-Tee
MGF	: Micro Gland-F	MCS	: Micro Cross
MGM	: Micro Gland-M	MTW	: Micro Tribow
CLC	: Close Coupling	MOE	: Micro 45Elbow
BHU	: Bulkhead Union	MRU	: Micro R-Union
DMU	: Double Male Union	LE	: Long Elbow
MUE	: Male Union Elbow	LT	: Long Tee
MC	: Male Connector	LRT	: Long R-Tee
MEC	: Male Elbow	LRU	: Long R-Union
MUT	: Male Union Tee		



Metal seal fittings



01 MALE NUT

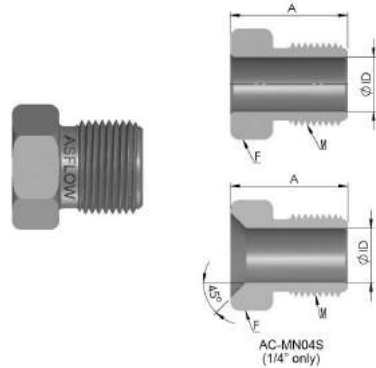

Head Size	Ordering Number	ID	A	F	M
1/4"	AC-MN04	9.10	18.30	15.90	9/16-18UNF
1/4"	AC-MN04S	9.10	18.30	15.90	9/16-18UNF
1/2"	AC-MN08	15.50	20.00	23.80	7/8-14UNF
3/4"	AC-MN12	22.60	25.40	33.30	1 1/4-18UNEF
1"	AC-MN16	30.50	30.20	41.30	1 1/2-20UN

02 FEMALE NUT

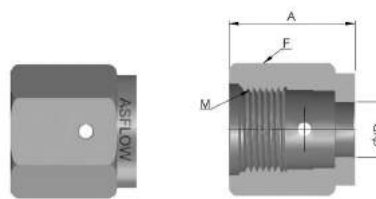

Head Size	Ordering Number	ID	A	F	M
1/4"	AC-FN04	9.10	20.75	19.05	9/16-18UNF
1/2"	AC-FN08	15.50	22.50	26.90	7/8-14UNF
3/4"	AC-FN12	22.60	28.50	38.10	1 1/4-18UNEF
1"	AC-FN16	30.50	34.00	44.50	1 1/2-20UN

03 GASKET

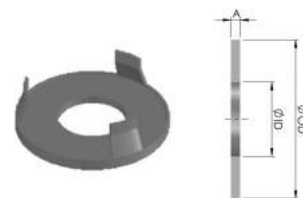

Materials : SUS 316L/Nickel

Head Size	Ordering Number	OD	ID	A
1/4"	AC-GSK04	11.84	5.49	0.75
1/2"	AC-GSK08	19.31	11.70	0.75
3/4"	AC-GSK12	28.00	16.87	0.75
1"	AC-GSK16	34.12	22.60	0.75

04 CAP

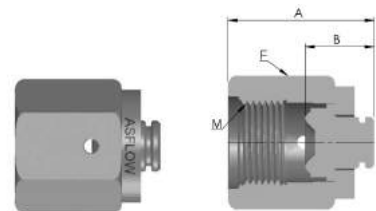

Head Size	Ordering Number	A	B	F	M
1/4"	AC-CP04	22.90	11.30	19.10	9/16-18UNF
1/2"	AC-CP08	25.60	12.20	27.00	7/8-14UNF
3/4"	AC-CP12	32.80	13.70	38.10	1 1/4-18UNEF
1"	AC-CP16	39.40	16.00	44.50	1 1/2-20UN

05 PLUG

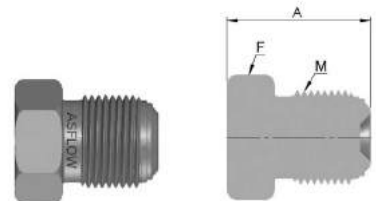

Head Size	Ordering Number	A	F	M
1/4"	AC-PG04	23.20	15.90	9/16-18UNF
1/2"	AC-PG08	27.30	23.80	7/8-14UNF
3/4"	AC-PG12	36.30	33.30	1 1/4-18UNEF
1"	AC-PG16	38.60	41.30	1 1/2-20UN

06 LONG GLAND-F

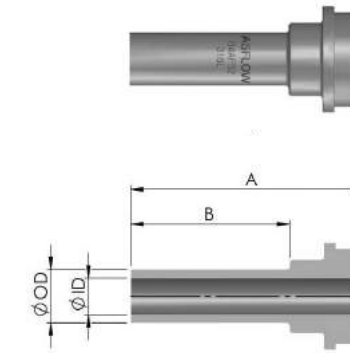

Head Size	Tube Size (OD)	Ordering Number	OD	ID	A	B	Working Pressure bar(psig)	
							NI	316L
1/4"	1/4"	AC-LGF04	6.35	4.35	28.00	19.05	351(5100)	
3/8"	3/8"	AC-LGF06	9.53	7.53	28.50	19.05	227(3300)	
1/2"	1/2"	AC-LGF08	12.70	10.22	28.50	19.05	241(3500)	
1/2"	1/4"	AC-LGF08-04	6.35	4.35	28.50	19.05	241(3500)	296(4300)
3/4"	3/4"	AC-LGF12	19.05	15.75	34.50	19.05	165(2400)	
3/4"	1/4"	AC-LGF12-04	6.35	4.35	30.55	19.05	165(2400)	
3/4"	3/8"	AC-LGF12-06	9.53	7.53	30.55	19.05	165(2400)	
3/4"	1/2"	AC-LGF12-08	12.70	10.22	30.55	19.05	165(2400)	
1"	1"	AC-LGF16	25.40	22.10	38.60	20.00	165(2400)	
1"	1/4"	AC-LGF16-04	6.35	4.35	34.15	20.00	165(2400)	
1"	3/8"	AC-LGF16-06	9.53	7.53	34.15	20.00	165(2400)	
1"	1/2"	AC-LGF16-08	12.70	10.22	34.15	20.00	165(2400)	
1"	3/4"	AC-LGF16-12	19.05	15.75	38.10	20.00	165(2400)	
1/4"	6M	AC-LGF04-6M	6.00	4.00	28.00	19.05	468(6800)	
1/4"	8M	AC-LGF04-8M	8.00	6.00	28.00	19.05	337(4900)	
1/2"	10M	AC-LGF08-10M	10.00	8.00	28.50	19.05	241(3500)	
1/2"	12M	AC-LGF08-12M	12.00	10.00	28.50	19.05	213(3100)	
3/4"	18M	AC-LGF12-18M	18.00	15.00	34.50	19.05	206(3000)	

07 LONG GLAND-M

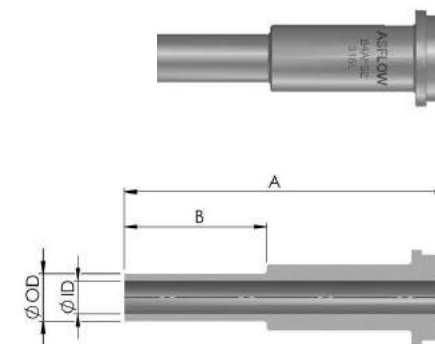

Head Size	Tube Size (OD)	Ordering Number	OD	ID	A	B	Working Pressure bar(psig)	
							NI	316L
1/4"	1/4"	AC-LGM04	6.35	4.35	43.20	19.05	351(5100)	
3/8"	3/8"	AC-LGM06	9.53	7.53	45.50	19.05	227(3300)	
1/2"	1/2"	AC-LGM08	12.70	10.22	45.50	19.05	241(3500)	
1/2"	1/4"	AC-LGM08-04	6.35	4.35	45.50	19.05	241(3500)	296(4300)
3/4"	3/4"	AC-LGM12	19.05	15.75	51.60	19.05	165(2400)	
3/4"	1/4"	AC-LGM12-04	6.35	4.35	47.65	19.05	165(2400)	
3/4"	3/8"	AC-LGM12-06	9.53	7.53	47.65	19.05	165(2400)	
3/4"	1/2"	AC-LGM12-08	12.70	10.22	47.65	19.05	165(2400)	
1"	1"	AC-LGM16	25.40	22.10	58.90	20.00	165(2400)	
1"	1/4"	AC-LGM16-04	6.35	4.35	54.45	20.00	165(2400)	
1"	3/8"	AC-LGM16-06	9.53	7.53	54.45	20.00	165(2400)	
1"	1/2"	AC-LGM16-08	12.70	10.22	54.45	20.00	165(2400)	
1"	3/4"	AC-LGM16-12	19.05	15.75	58.40	20.00	165(2400)	
1/4"	6M	AC-LGM04-6M	6.00	4.00	43.20	19.05	468(6800)	
1/4"	8M	AC-LGM04-8M	8.00	6.00	43.20	19.05	337(4900)	
1/2"	10M	AC-LGM08-10M	10.00	8.00	45.50	19.05	241(3500)	
1/2"	12M	AC-LGM08-12M	12.00	10.00	45.50	19.05	213(3100)	
3/4"	18M	AC-LGM12-18M	18.00	15.00	51.60	19.05	206(3000)	



08 ATW LONG GLAND-F

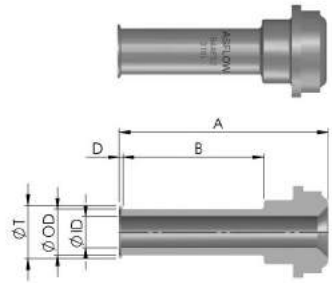

Head Size	Tube Size (OD)	Ordering Number	OD	ID	A	B	D	T	Working Pressure bar(psig)	
									NI	316L
1/4"	1/4"	AC-ALGF04	6.35	4.35	28.50	19.05	0.50	7.37	351(5100)	
3/8"	3/8"	AC-ALGF06	9.53	7.53	29.26	19.05	0.75	10.41	227(3300)	
1/2"	1/2"	AC-ALGF08	12.70	10.22	29.52	19.05	1.02	13.97	241(3500)	
1/2"	1/4"	AC-ALGF08-04	6.35	4.35	29.00	19.05	0.50	7.37	241(3500)	

09 ATW LONG GLAND-M

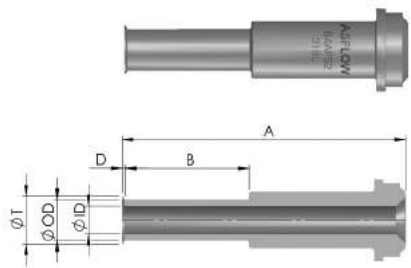

Head Size	Tube Size (OD)	Ordering Number	OD	ID	A	B	D	T	Working Pressure bar(psig)	
									NI	316L
1/4"	1/4"	AC-ALGM04	6.35	4.35	43.70	19.05	0.50	7.37	351(5100)	
3/8"	3/8"	AC-ALGM06	9.53	7.53	46.26	19.05	0.75	10.41	227(3300)	
1/2"	1/2"	AC-ALGM08	12.70	10.22	46.52	19.05	1.02	13.97	241(3500)	
1/2"	1/4"	AC-ALGM08-04	6.35	4.35	46.00	19.05	0.50	7.37	241(3500)	
3/4"	3/4"	AC-ALGM12	19.05	15.75	52.62	19.05	1.02	20.32	165(2400)	
1"	1"	AC-ALGM16	25.40	22.10	59.92	19.05	1.02	26.92	165(2400)	

10 MICRO GLAND-F

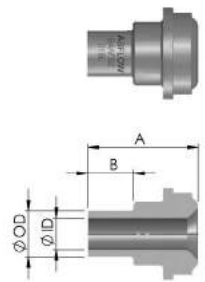

Head Size	Tube Size (OD)	Ordering Number	OD	ID	A	B	Working Pressure bar(psig)	
							NI	316L
1/4"	1/4"	AC-MGF04	6.35	4.35	15.30	6.35	351(5100)	
3/8"	3/8"	AC-MGF06	9.53	7.53	15.80	6.35	227(3300)	
1/2"	1/2"	AC-MGF08	12.70	10.22	15.80	6.35	241(3500)	
1/2"	1/4"	AC-MGF08-04	6.35	4.35	15.80	6.35	241(3500)	296(4300)
1/4"	6M	AC-MGF04-6M	6.00	4.00	15.30	6.35	468(6800)	
1/4"	8M	AC-MGF04-8M	8.00	6.00	15.30	6.35	337(4900)	
1/2"	10M	AC-MGF08-10M	10.00	8.00	15.80	6.35	241(3500)	
1/2"	12M	AC-MGF08-12M	12.00	10.00	15.80	6.35	213(3100)	

11 MICRO GLAND-M

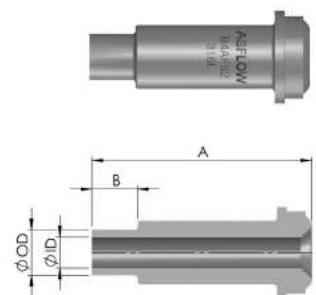

Head Size	Tube Size (OD)	Ordering Number	OD	ID	A	B	Working Pressure bar(psig)	
							NI	316L
1/4"	1/4"	AC-MGM04	6.35	4.35	30.50	6.35	351(5100)	
3/8"	3/8"	AC-MGM06	9.53	7.53	32.80	6.35	227(3300)	
1/2"	1/2"	AC-MGM08	12.70	10.22	32.80	6.35	241(3500)	
1/2"	1/4"	AC-MGM08-04	6.35	4.35	32.80	6.35	241(3500)	296(4300)
1/4"	6M	AC-MGM04-6M	6.00	4.00	30.50	6.35	468(6800)	
1/4"	8M	AC-MGM04-8M	8.00	6.00	30.50	6.35	337(4900)	
1/2"	10M	AC-MGM08-10M	10.00	8.00	32.80	6.35	241(3500)	
1/2"	12M	AC-MGM08-12M	12.00	10.00	32.80	6.35	213(3100)	

12 CLOSE COUPLING

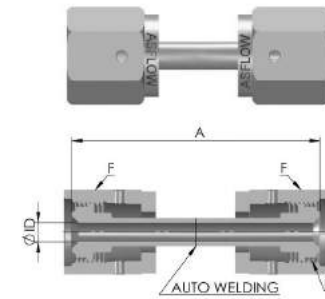

Head Size	Tube Size (OD)	Ordering Number	ID	A	F	M	Working Pressure bar(psig)	
							NI	316L
1/4"	1/4"	AC-CLC04	4.35	56.00	19.10	9/16-18UNF	551(8000)	689(10000)
1/2"	1/2"	AC-CLC08	10.22	57.00	26.90	7/8-14UNF	241(3500)	296(4300)

13 BULKHEAD UNION

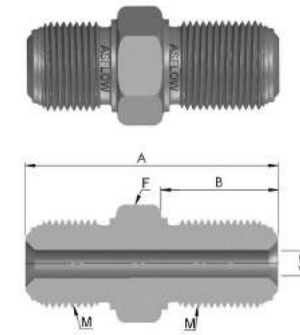

Head Size	Ordering Number	ID	A	B	F	M	Working Pressure bar(psig)	
							NI	316L
1/4"	AC-BU04	4.35	56.60	33.40	19.10	9/16-18UNF	551(8000)	689(10000)
1/2"	AC-BU08	10.22	65.30	37.60	27.00	7/8-14UNF	241(3500)	296(4300)
3/4"	AC-BU12	15.75	79.00	43.00	38.00	1 1/4-18UNEF	206(3000)	254(3700)
1"	AC-BU16	22.10	86.00	47.00	44.40	1 1/2-20UN	165(2400)	206(3000)

14 DOUBLE MALE UNION

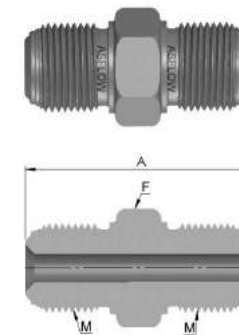

Head Size	Ordering Number	ID	A	F	M	Working Pressure bar(psig)	
						NI	316L
1/4"	AC-DMU04	4.35	39.40	15.90	9/16-18UNF	551(8000)	689(10000)
1/2"	AC-DMU08	10.22	47.30	23.80	7/8-14UNF	241(3500)	296(4300)
3/4"	AC-DMU12	15.75	62.00	33.30	1 1/4-18UNEF	206(3000)	254(3700)
1"	AC-DMU16	22.10	65.80	41.30	1 1/2-20UN	165(2400)	206(3000)

15 MALE UNION ELBOW

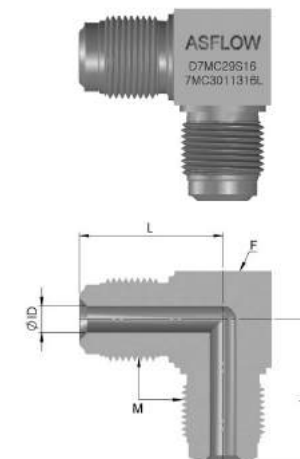

Head Size	Ordering Number	ID	L	F	M	Working Pressure bar(psig)	
						NI	316L
1/4"	AC-MUE04	4.35	27.00	16.00	9/16-18UNF	551(8000)	689(10000)
1/2"	AC-MUE08	10.22	36.80	24.00	7/8-14UNF	241(3500)	296(4300)
3/4"	AC-MUE12	15.75	48.77	33.30	1 1/4-18UNEF	206(3000)	254(3700)
1"	AC-MUE16	22.10	50.80	42.80	1 1/2-20UN	165(2400)	206(3000)



16 MALE CONNECTOR

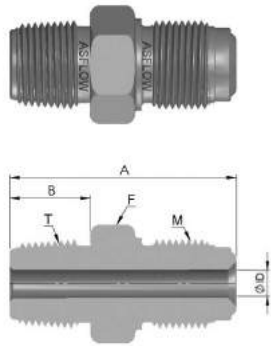

Head Size	T-NPT Size	Ordering Number	ID	A	B	F	M	Working Pressure bar(psig)	
								NI	316L
1/4"	1/4" NPT	AC-MC04	4.35	37.84	14.22	15.90	9/16-18UNF	551(8000)	689(10000)
1/2"	1/2" NPT	AC-MC08	10.22	46.74	19.05	23.80	7/8-14UNF	241(3500)	296(4300)
1/2"	1/4" NPT	AC-MC08-04	4.35	41.90	14.22	23.80	7/8-14UNF	241(3500)	296(4300)
1/2"	3/8" NPT	AC-MC08-06	7.53	41.90	14.22	23.80	7/8-14UNF	241(3500)	296(4300)
3/4"	3/4" NPT	AC-MC12	15.75	55.63	19.05	33.30	1 1/4-18UNEF	206(3000)	254(3700)
3/4"	1/4" NPT	AC-MC12-04	4.35	50.80	14.22	33.30	1 1/4-18UNEF	206(3000)	254(3700)
3/4"	3/8" NPT	AC-MC12-06	7.53	50.80	14.22	33.30	1 1/4-18UNEF	206(3000)	254(3700)
3/4"	1/2" NPT	AC-MC12-08	10.22	55.63	19.05	33.30	1 1/4-18UNEF	206(3000)	254(3700)
1"	1" NPT	AC-MC16	22.10	62.74	23.88	41.30	1 1/2-20UN	165(2400)	206(3000)
1"	1/4" NPT	AC-MC16-04	4.35	53.08	14.22	41.30	1 1/2-20UN	165(2400)	206(3000)
1"	3/8" NPT	AC-MC16-06	7.53	53.08	14.22	41.30	1 1/2-20UN	165(2400)	206(3000)
1"	1/2" NPT	AC-MC16-08	10.22	57.90	19.05	41.30	1 1/2-20UN	165(2400)	206(3000)
1"	3/4" NPT	AC-MC16-12	15.75	57.90	19.05	41.30	1 1/2-20UN	165(2400)	206(3000)

17 MALE ELBOW

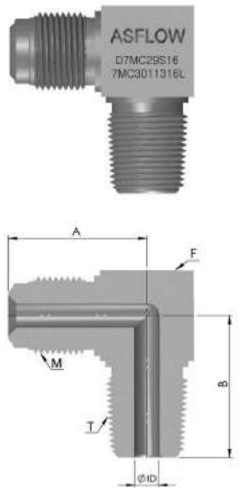

Head Size	T-NPT Size	Ordering Number	ID	A	B	F	M	Working Pressure bar(psig)	
								NI	316L
1/4"	1/4" NPT	AC-MEC04	4.35	27.00	26.67	16.00	9/16-18UNF	551(8000)	551(8000)
1/2"	1/2" NPT	AC-MEC08	10.22	36.80	36.83	24.00	7/8-14UNF	241(3500)	296(4300)
1/2"	1/4" NPT	AC-MEC08-04	4.35	36.80	26.22	24.00	7/8-14UNF	241(3500)	296(4300)
1/2"	3/8" NPT	AC-MEC08-06	7.53	36.80	26.22	24.00	7/8-14UNF	241(3500)	296(4300)
3/4"	3/4" NPT	AC-MEC12	15.75	48.77	43.50	33.30	1 1/4-18UNEF	206(3000)	254(3700)
3/4"	1/4" NPT	AC-MEC12-04	4.35	48.77	30.87	33.30	1 1/4-18UNEF	206(3000)	254(3700)
3/4"	3/8" NPT	AC-MEC12-06	7.53	48.77	30.87	33.30	1 1/4-18UNEF	206(3000)	254(3700)
3/4"	1/2" NPT	AC-MEC12-08	10.22	48.77	35.70	33.30	1 1/4-18UNEF	206(3000)	254(3700)
1"	1" NPT	AC-MEC16	22.10	50.80	45.28	42.80	1 1/2-20UN	165(2400)	206(3000)
1"	1/4" NPT	AC-MEC16-04	4.35	50.80	35.62	42.80	1 1/2-20UN	165(2400)	206(3000)
1"	3/8" NPT	AC-MEC16-06	7.53	50.80	35.62	42.80	1 1/2-20UN	165(2400)	206(3000)
1"	1/2" NPT	AC-MEC16-08	10.22	50.80	40.90	42.80	1 1/2-20UN	165(2400)	206(3000)
1"	3/4" NPT	AC-MEC16-12	15.75	50.80	40.90	42.80	1 1/2-20UN	165(2400)	206(3000)

18 MALE UNION TEE

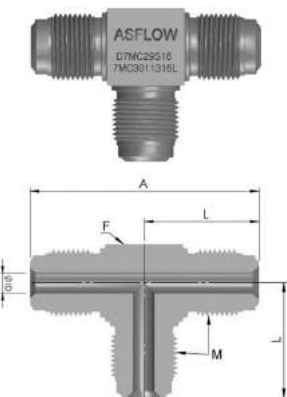

Head Size	Ordering Number	ID	A	L	F	M	Working Pressure bar(psig)	
							NI	316L
1/4"	AC-MUT04	4.35	54.00	27.00	16.00	9/16-18UNF	551(8000)	689(10000)
1/2"	AC-MUT08	10.22	73.60	36.80	24.00	7/8-14UNF	241(3500)	296(4300)

19 MALE UNION CROSS

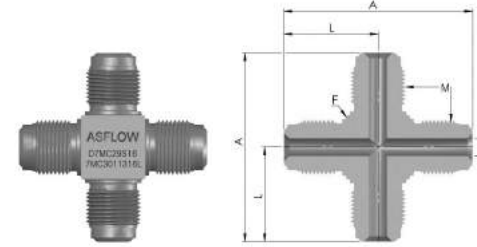

Head Size	Ordering Number	ID	A	L	F	M	Working Pressure bar(psig)	
							NI	316L
1/4"	AC-MUC04	4.35	54.00	27.00	16.00	9/16-18UNF	551(8000)	689(10000)
1/2"	AC-MUC08	10.22	73.60	36.80	24.00	7/8-14UNF	241(3500)	296(4300)

20 B/W CONNECTOR

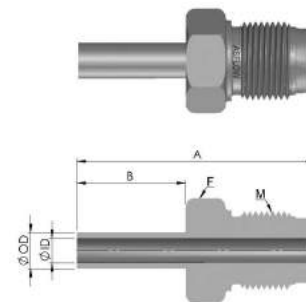

Head Size	Tube Size(OD)	Ordering Number	OD	ID	A	B	F	M	Working Pressure bar(psig)	
									NI	316L
1/4"	1/4"	AC-BWC04	6.35	4.35	42.67	19.05	15.9	9/16-18UNF		351(5100)
1/2"	1/2"	AC-BWC08	12.70	10.22	46.72	19.05	23.8	7/8-14UNF		254(3700)
1/2"	1/4"	AC-BWC08-04	6.35	4.35	46.72	19.05	23.8	7/8-14UNF		254(3700)
1/2"	3/8"	AC-BWC08-06	9.53	7.53	46.72	19.05	23.8	7/8-14UNF		227(3300)

21 HVCR GLAND

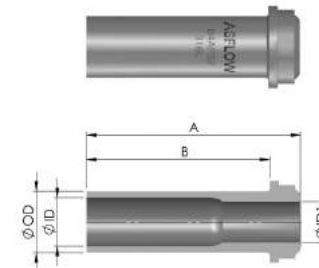

Head Size	Tube Size(OD)	Ordering Number	OD	ID	ID1	A	B	Working Pressure bar(psig)	
								NI	316L
1/4"	3/8"	AC-HG06	9.53	7.53	6.35	33.20	28.40		227(3300)

22 HVCR MALE NUT

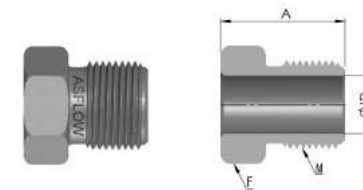

Head Size	Ordering Number	ID	A	F	M
1/4"	AC-HMN04	9.90	18.30	15.90	9/16-18UNF

23 HVCR FEMALE NUT

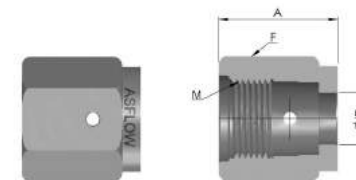

Head Size	Ordering Number	ID	A	F	M
1/4"	AC-HFN04	9.90	20.75	19.05	9/16-18UNF



Weld fittings

Clean Fittings

Weld fittings



24 MICRO ELBOW

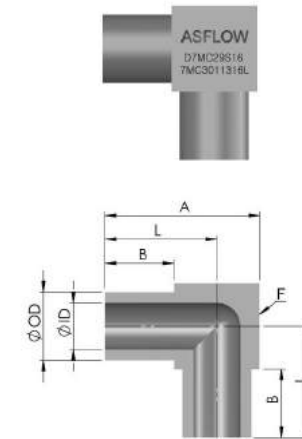

Size (OD)	Ordering Number	OD	ID	A	B	L	F	Working Pressure bar(psig)
1/4"	AC-ME04	6.35	4.35	14.29	6.35	10.32	7.94	351(5100)
3/8"	AC-ME06	9.53	7.53	17.46	6.35	11.91	11.11	227(3300)
1/2"	AC-ME08	12.70	10.22	20.64	6.35	13.50	14.29	254(3700)
3/4"	AC-ME12	19.05	15.75	27.00	6.35	16.68	20.65	165(2400)
6M	AC-ME6M	6.00	4.00	14.29	6.35	10.32	7.94	420(6095)
8M	AC-ME8M	8.00	6.00	17.46	6.35	11.91	11.11	310(4499)
10M	AC-ME10M	10.00	8.00	17.46	6.35	11.91	11.11	240(3483)
12M	AC-ME12M	12.00	10.00	20.64	6.35	13.50	14.29	200(2902)

25 MICRO R-ELBOW

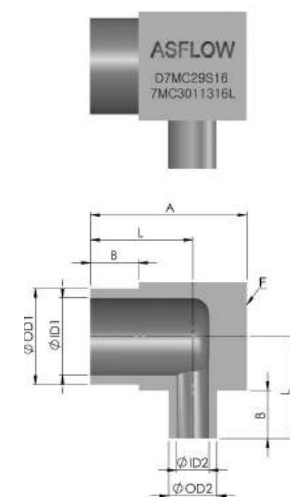

Size (OD1)	Size (OD2)	Ordering Number	OD		ID		A	B	L	F	Working Pressure bar(psig)
			OD1	OD2	ID1	ID2					
3/8"	1/4"	AC-MRE06-04	9.53	6.35	7.53	4.35	17.46	6.35	11.91	11.11	227(3300)
1/2"	1/4"	AC-MRE08-04	12.70	6.35	10.22	4.35	20.64	6.35	13.50	14.29	254(3700)
1/2"	3/8"	AC-MRE08-06	12.70	9.53	10.22	7.53	20.64	6.35	13.50	14.29	227(3300)
8M	6M	AC-MRE8M-6M	8.00	6.00	6.00	4.00	17.46	6.35	11.91	11.11	310(4499)
12M	6M	AC-MRE12M-6M	12.00	6.00	10.00	4.00	20.64	6.35	13.50	14.29	200(2902)
12M	8M	AC-MRE12M-8M	12.00	8.00	10.00	6.00	20.64	6.35	13.50	14.29	200(2902)

26 MICRO TEE

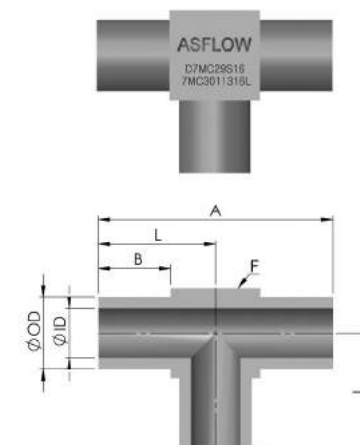

Size (OD)	Ordering Number	OD	ID	A	B	L	F	Working Pressure bar(psig)
1/4"	AC-MT04	6.35	4.35	20.64	6.35	10.32	7.94	351(5100)
3/8"	AC-MT06	9.53	7.53	23.81	6.35	11.91	11.11	227(3300)
1/2"	AC-MT08	12.7	10.22	26.99	6.35	13.50	14.29	254(3700)
3/4"	AC-MT12	19.05	15.75	33.35	6.35	16.68	20.65	165(2400)
6M	AC-MT6M	6.00	4.00	20.64	6.35	10.32	7.94	420(6095)
8M	AC-MT8M	8.00	6.00	23.81	6.35	11.91	11.11	310(4499)
10M	AC-MT10M	10.00	8.00	23.81	6.35	11.91	11.11	240(3483)
12M	AC-MT12M	12.00	10.00	26.99	6.35	13.50	14.29	200(2902)



27 MICRO R-TEE

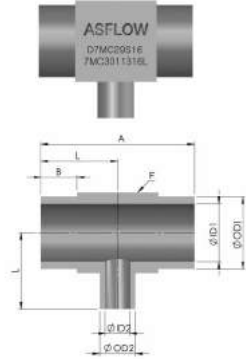

Size (OD1)	Size (OD2)	Ordering Number	OD		ID		A	B	L	F	Working Pressure bar(psig)
			OD1	OD2	ID1	ID2					
3/8"	1/4"	AC-MRT06-04	9.53	6.35	7.53	4.35	23.81	6.35	11.91	11.11	227(3300)
1/2"	1/4"	AC-MRT08-04	12.70	6.35	10.22	4.35	26.99	6.35	13.50	14.29	254(3700)
1/2"	3/8"	AC-MRT08-06	12.70	9.53	10.22	7.53	26.99	6.35	13.50	14.29	227(3300)
8M	6M	AC-MRT8M-6M	8.00	6.00	6.00	4.00	23.81	6.35	11.91	11.11	310(4499)
12M	6M	AC-MRT12M-6M	12.00	6.00	10.00	4.00	26.99	6.35	13.50	14.29	200(2902)
12M	8M	AC-MRT12M-8M	12.00	8.00	10.00	6.00	26.99	6.35	13.50	14.29	200(2902)

28 MICRO CROSS

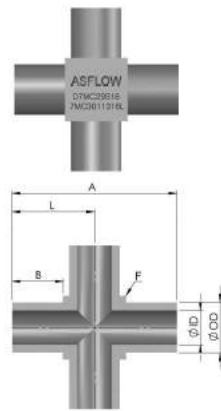

Size (OD)	Ordering Number	OD	ID	A	B	L	F	Working Pressure bar(psig)
1/4"	AC-MCS04	6.35	4.35	20.64	6.35	10.32	7.94	351(5100)
3/8"	AC-MCS06	9.53	7.53	23.81	6.35	11.91	11.11	227(3300)
1/2"	AC-MCS08	12.70	10.22	26.99	6.35	13.50	14.29	254(3700)
6M	AC-MCS6M	6.00	4.00	20.64	6.35	10.32	7.94	420(6095)
8M	AC-MCS8M	8.00	6.00	23.81	6.35	11.91	11.11	310(4499)
10M	AC-MCS10M	10.00	8.00	23.81	6.35	11.91	11.11	240(3483)
12M	AC-MCS12M	12.00	10.00	26.99	6.35	13.50	14.29	200(2902)

29 MICRO TRIBOW

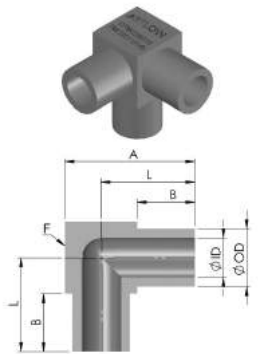

Size (OD)	Ordering Number	OD	ID	A	B	L	F	Working Pressure bar(psig)
1/4"	AC-MTW04	6.35	4.35	14.29	6.35	10.32	7.94	351(5100)
3/8"	AC-MTW06	9.53	7.53	17.46	6.35	11.91	11.11	227(3300)
1/2"	AC-MTW08	12.70	10.22	20.64	6.35	13.50	14.29	254(3700)

30 MICRO 45 ELBOW

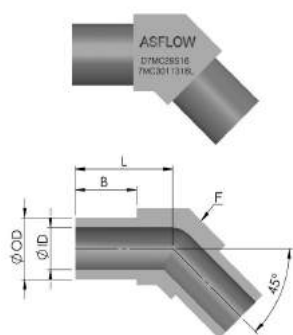

Size (OD)	Ordering Number	OD	ID	B	L	F	Working Pressure bar(psig)
1/4"	AC-MOE04	6.35	4.35	6.35	10.10	7.94	351(5100)
3/8"	AC-MOE06	9.53	7.53	6.35	11.91	11.11	227(3300)
1/2"	AC-MOE08	12.70	10.22	6.35	13.49	14.29	254(3700)
6M	AC-MOE6M	6.00	4.00	6.35	10.10	7.94	420(6095)
8M	AC-MOE8M	8.00	6.00	6.35	11.91	11.11	310(4499)
10M	AC-MOE10M	10.00	8.00	6.35	11.91	11.11	240(3483)
12M	AC-MOE12M	12.00	10.00	6.35	13.49	14.29	200(2902)

31 MICRO R-UNION

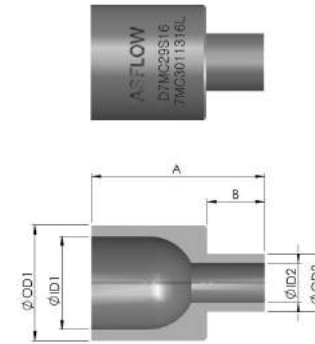

Size (OD1)	Size (OD2)	Ordering Number	OD		ID		A	B	Working Pressure bar(psig)
			OD1	OD2	ID1	ID2			
3/8"	1/4"	AC-MRU06-04	9.53	6.35	7.53	4.35	19.05	6.35	227(3300)
1/2"	1/4"	AC-MRU08-04	12.70	6.35	10.22	4.35	19.05	6.35	254(3700)
1/2"	3/8"	AC-MRU08-06	12.70	9.53	10.22	7.53	19.05	6.35	227(3300)
8M	6M	AC-MRU8M-6M	8.00	6.00	6.00	4.00	19.05	6.35	310(4499)
10M	6M	AC-MRU10M-6M	10.00	6.00	8.00	4.00	19.05	6.35	240(3483)
10M	8M	AC-MRU10M-8M	10.00	8.00	8.00	6.00	19.05	6.35	240(3483)
12M	6M	AC-MRU12M-6M	12.00	6.00	10.00	4.00	19.05	6.35	200(2902)
12M	8M	AC-MRU12M-8M	12.00	8.00	10.00	6.00	19.05	6.35	200(2902)
12M	10M	AC-MRU12M-10M	12.00	10.00	10.00	8.00	19.05	6.35	200(2902)

32 LONG ELBOW

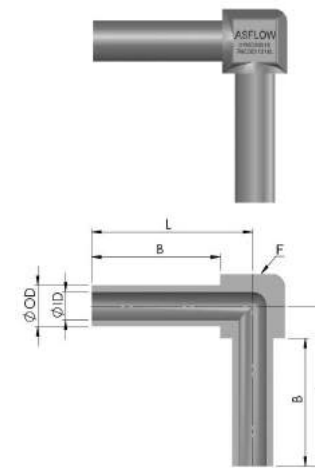

Size (OD)	Ordering Number	OD	ID	B	L	F	Working Pressure bar(psig)
1/4"	AC-LE04	6.35	4.35	20.00	25.00	10.00	351(5100)
3/8"	AC-LE06	9.53	7.53	20.00	26.00	12.50	227(3300)
1/2"	AC-LE08	12.70	10.22	20.00	28.00	16.00	254(3700)
3/4"	AC-LE12	19.05	15.75	23.00	34.00	22.00	165(2400)
1"	AC-LE16	25.40	22.10	23.50	37.50	28.50	165(2400)
6M	AC-LE6M	6.00	4.00	20.00	25.00	10.00	420(6095)
8M	AC-LE8M	8.00	6.00	20.00	26.00	12.50	310(4499)
10M	AC-LE10M	10.00	8.00	20.00	28.00	16.00	240(3483)
12M	AC-LE12M	12.00	10.00	20.00	28.00	16.00	200(2902)
18M	AC-LE18M	18.00	15.00	23.00	34.00	22.00	200(2902)

33 LONG TEE

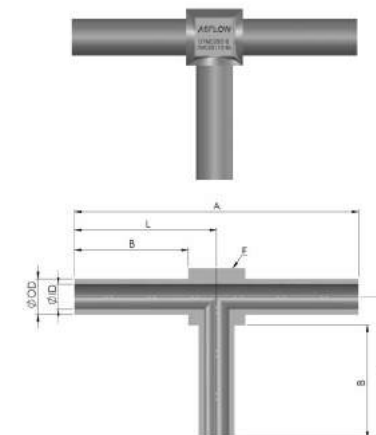

Size (OD)	Ordering Number	OD	ID	A	B	L	F	Working Pressure bar(psig)
1/4"	AC-LT04	6.35	4.35	50.00	20.00	25.00	10.00	351(5100)
3/8"	AC-LT06	9.53	7.53	52.00	20.00	26.00	12.50	227(3300)
1/2"	AC-LT08	12.70	10.22	56.00	20.00	28.00	16.00	254(3700)
3/4"	AC-LT12	19.05	15.75	68.00	23.00	34.00	22.00	165(2400)
1"	AC-LT16	25.40	22.10	75.00	23.50	37.50	28.50	165(2400)
6M	AC-LT6M	6.00	4.00	50.00	20.00	25.00	10.00	420(6095)
8M	AC-LT8M	8.00	6.00	52.00	20.00	26.00	12.50	310(4499)
10M	AC-LT10M	10.00	8.00	56.00	20.00	28.00	16.00	240(3483)
12M	AC-LT12M	12.00	10.00	56.00	20.00	28.00	16.00	200(2902)
18M	AC-LT18M	18.00	15.00	68.00	23.00	34.00	22.00	200(2902)



34 LONG REDUCING TEE

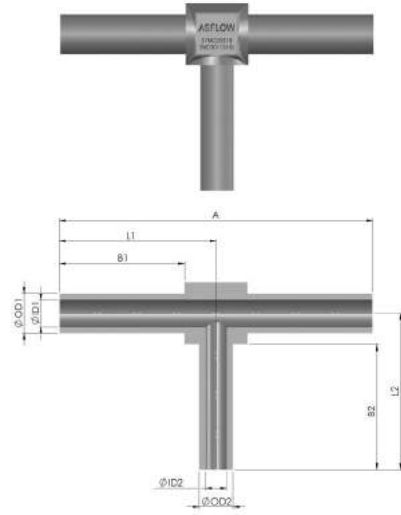

Size (OD1)	Size (OD2)	Ordering Number	OD		ID		A	B1	L1	B2	L2	F	Working Pressure bar(psig)
			OD1	OD2	ID1	ID2							
3/8"	1/4"	AC-LRT06-04	9.53	6.35	7.53	4.35	52.00	20.00	26.00	20.00	26.00	12.50	227(3300)
1/2"	1/4"	AC-LRT08-04	12.70	6.35	10.22	4.35	56.00	20.00	28.00	20.00	28.00	16.00	254(3700)
1/2"	3/8"	AC-LRT08-06	12.70	9.53	10.22	7.53	56.00	20.00	28.00	20.00	28.00	16.00	227(3300)
3/4"	1/4"	AC-LRT12-04	19.05	6.35	15.75	4.35	68.00	23.00	34.00	20.00	31.00	22.00	165(2400)
3/4"	3/8"	AC-LRT12-06	19.05	9.53	15.75	7.53	68.00	23.00	34.00	20.00	31.00	22.00	165(2400)
3/4"	1/2"	AC-LRT12-08	19.05	12.70	15.75	10.22	68.00	23.00	34.00	20.00	31.00	22.00	165(2400)
1"	1/4"	AC-LRT16-04	25.40	6.35	22.10	4.35	75.00	23.50	37.50	20.00	34.00	28.50	165(2400)
1"	3/8"	AC-LRT16-06	25.40	9.53	22.10	7.53	75.00	23.50	37.50	20.00	34.00	28.50	165(2400)
1"	1/2"	AC-LRT16-08	25.40	12.70	22.10	10.22	75.00	23.50	37.50	20.00	34.00	28.50	165(2400)
1"	3/4"	AC-LRT16-12	25.40	19.05	22.10	15.75	75.00	23.50	37.50	23.00	37.00	28.50	165(2400)

35 LONG REDUCING UNION

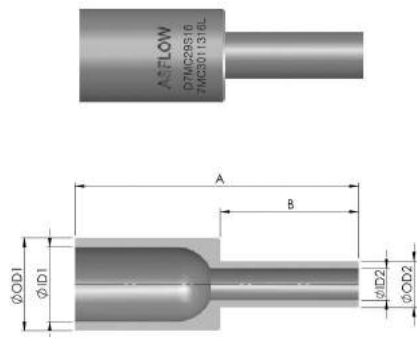

Size (OD1)	Size (OD2)	Ordering Number	OD		ID		A	B	Working Pressure bar(psig)
			OD1	OD2	ID1	ID2			
3/8"	1/4"	AC-LRU06-04	9.53	6.35	7.53	4.35	39.00	19.00	227(3300)
1/2"	1/4"	AC-LRU08-04	12.70	6.35	10.22	4.35	39.00	19.00	254(3700)
1/2"	3/8"	AC-LRU08-06	12.70	9.53	10.22	7.53	39.00	19.00	227(3300)
3/4"	1/4"	AC-LRU12-04	19.05	6.35	15.75	4.35	42.90	19.00	165(2400)
3/4"	3/8"	AC-LRU12-06	19.05	9.53	15.75	7.53	42.90	19.00	165(2400)
3/4"	1/2"	AC-LRU12-08	19.05	12.70	15.75	10.22	42.90	19.00	165(2400)
1"	1/4"	AC-LRU16-04	25.40	6.35	22.10	4.35	44.50	19.00	165(2400)
1"	3/8"	AC-LRU16-06	25.40	9.53	22.10	7.53	44.50	19.00	165(2400)
1"	1/2"	AC-LRU16-08	25.40	12.70	22.10	10.22	44.50	19.00	165(2400)
1"	3/4"	AC-LRU16-12	25.40	19.05	22.10	15.75	48.50	23.00	165(2400)
8M	6M	AC-LRU8M-6M	8.00	6.00	6.00	4.00	39.00	19.00	310(4499)
10M	6M	AC-LRU10M-6M	10.00	6.00	8.00	4.00	39.00	19.00	240(3483)
10M	8M	AC-LRU10M-8M	10.00	8.00	8.00	6.00	39.00	19.00	240(3483)
12M	6M	AC-LRU12M-6M	12.00	6.00	10.00	4.00	39.00	19.00	200(2902)
12M	8M	AC-LRU12M-8M	12.00	8.00	10.00	6.00	39.00	19.00	200(2902)
12M	10M	AC-LRU12M-10M	12.00	10.00	10.00	8.00	39.00	19.00	200(2902)
18M	6M	AC-LRU18M-6M	18.00	6.00	15.00	4.00	42.90	19.00	200(2902)
18M	8M	AC-LRU18M-8M	18.00	8.00	15.00	6.00	42.90	19.00	200(2902)
18M	10M	AC-LRU18M-10M	18.00	10.00	15.00	8.00	42.90	19.00	200(2902)
18M	12M	AC-LRU18M-12M	18.00	12.00	15.00	10.00	42.90	19.00	200(2902)

I Assembly Instruction I

Retainer Assembly

Step 1

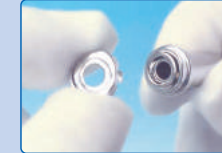

While tightening fittings, make sure seal parts and gaskets are free of scratch and dirt.

Non - Retainer Assembly

Step 1



Insert gasket into female nut and make sure the gasket is settled in proper position. Also make sure no damages on seal part while inserting

Step 2



Turn female nut until it comes into contact with male nut. And make sure seal part and gasket are placed in proper position

Step 3



Final tightening shall be completed by assembly tools such as tools such as two spanners. Tighten the female nut 1/8-1/6 turns with second spanner and make sure that components screwing except female nut could damage the seal part to reduce the seal capacity.

Step 4



Make sure seal part and gasket are placed in proper position.